

Face Detection Camera User Manual



Issue

V1.0

Date

2019-03-06





Precautions

Precautions

Fully understand this document before using this device, and strictly observe rules in this document when using this device. If you install this device in public places, provide the tip "You have entered the area of electronic surveillance" in an eye-catching place. Failure to correctly use electrical products may cause fire and severe injuries. To prevent accidents, carefully read the following context:

Symbols

This document may contain the following symbols whose meanings are described accordingly.

Symbol	Description
 DANGER	It alerts you to fatal dangers which, if not avoided, may cause deaths or severe injuries.
 WARNING	It alerts you to moderate dangers which, if not avoided, may cause minor or moderate injuries.
 CAUTION	It alerts you to risks. Neglect of these risks may cause device damage, data loss, device performance deterioration, or unpredictable results.
 TIP	It provides a tip that may help you resolve problems or save time.
 NOTE	It provides additional information.

DANGER

To prevent electric shocks or other dangers, keep power plugs dry and clean.

WARNING

- Strictly observe installation requirements when installing the device. The manufacturer shall not be held responsible for device damage caused by users' non-conformance to these requirements.

- Strictly conform to local electrical safety standards and use power adapters that are marked with the LPS standard when installing and using this device. Otherwise, this device may be damaged.
- Use accessories delivered with this device. The voltage must meet input voltage requirements for this device.
- If this device is installed in places with unsteady voltage, ground this device to discharge high energy such as electrical surges in order to prevent the power supply from burning out.
- When this device is in use, ensure that no water or any liquid flows into the device. If water or liquid unexpectedly flows into the device, immediately power off the device and disconnect all cables (such as power cables and network cables) from this device.
- If this device is installed in places where thunder and lightning frequently occur, ground the device nearby to discharge high energy such as thunder strikes in order to prevent device damage.

**CAUTION**

- During the outdoor installation, prevent the morning or evening sunlight incidence to the lens of the thermal imaging camera. The sun shade must be installed and adjusted according to the angle of the sunlight illumination.
- Avoid heavy loads, intensive shakes, and soaking to prevent damages during transportation and storage. The warranty does not cover any device damage that is caused during secondary packaging and transportation after the original packaging is taken apart.
- This device is a static sensitivity device. Improper static may damage the thermal imaging camera. ESD protection measures and reliable grounding must be well prepared for device installation and uninstallation.
- Protect this device from fall-down and intensive strikes, keep the device away from magnetic field interference, and do not install the device in places with shaking surfaces or under shocks.
- Use a soft and dry cloth to clean the device body. In case that the dirt is hard to remove, use a dry cloth dipped in a small amount of mild detergent and gently wipe the device, and then dry it again. Pay special attention to the front window of the thermal imaging camera because this is precision optics. If the front window has water spots, use a clean and soft cloth to moisten with water and wipe it. If the front window needs further cleaning, use a soft cloth dampened with isopropyl alcohol or detergent. Improper cleaning can cause damage to the device.
- Do not jam the ventilation opening. Follow the installation instructions provided in this document when installing the device.
- Keep the device away from heat sources such as radiators, electric heaters, or other heat equipment.

- Keep the device away from moist, dusty, extremely hot or cold places, or places with strong electric radiation.
- If the device is installed outdoors, take insect- and moisture-proof measures to avoid circuit board corrosion that can affect monitoring.
- Remove the power plug if the device is idle for a long time.
- Before unpacking, check whether the fragile sticker is damaged. If the fragile sticker is damaged, contact customer services or sales personnel. The manufacturer shall not be held responsible for any artificial damage of the fragile sticker.

Special Announcement

All complete products sold by the manufacturer are delivered along with nameplates, operation instructions, and accessories after strict inspection. The manufacturer shall not be held responsible for counterfeit products.

This manual may contain misprints, technology information that is not accurate enough, or product function and operation description that is slightly inconsistent with the actual product. The manufacturer will update this manual according to product function enhancement or changes and regularly update the software and hardware described in this manual. Update information will be added to new versions of this manual without prior notice.

This manual is only for reference and does not ensure that the information is totally consistent with the actual product. For consistency, please see the actual product.

Contents

1 Product Overview	6
1.1 About Camera.....	6
1.1.1 Principles and Advantages	6
1.1.2 System Overview	6
1.1.3 Application Scenario	7
1.1.4 Functions.....	7
1.1.5 Installation.....	8
1.2 Appearance.....	10
1.3 Login and Logout	11
1.4 Main Page layout.....	12
1.5 Change the Password.....	13
1.6 Browse Video	14
1.1.1 Install Plugins.....	16
1.7 Setting Local Network Parameters	17
2 Sensor Setting.....	20
2.1 Access the Sensor Setting Interface.....	20
2.2 Time Segment.....	21
2.3 Image Setting	21
2.4 Scene Mode.....	23
2.5 Exposure.....	24
2.6 WB Setting.....	26
2.7 Daynight.....	28
2.8 Noise Reduction.....	32
2.9 Enhance Image	34
3 Configure Face Detection	37
4 Intelligent Analysis	40
4.1 Perimeter	40
4.2 Single Virtual Fence	43
4.3 Double Virtual Fences	45
4.4 Multiple Loiter	48

4.5 Converse.....	51
4.6 Personnel Count	53

1 Product Overview

1.1 About Camera

1.1.1 Principles and Advantages

The face detection network camera has built-in high-performance GPU module and optimized deep learning algorithm. It is designed for video surveillance scenes. It has more accurate security big data induction ability than the brain, and realizes face information extraction in various complex environments. It can detect 30 faces at the same time, with better environmental adaptability and more accurate face detection.

The environment of camera is easy to set up, and the configuration is also very convenient. It can be directly installed and used by the dedicated video surveillance client that comes with the machine, or directly using a web browser to log in, and can also access the industry monitoring platform, flexible networking. Convenient. The camera can directly detect the moving face and output the optimal face capture, and simultaneously compare the captured face with the list face and output the result.

The advantage of face detection lies in its naturalness and characteristics that are not perceived by the individual being tested.

The so-called naturalness means that the detection method is the same as that used by humans (or even other organisms) for individual detection. For example, face detection, humans also observe and compare face recognition and identity, in addition to natural detection, voice detection, body shape detection, etc., and fingerprint detection, iris detection, etc. are not natural, because human or other Creatures do not distinguish individuals by such biological characteristics.

Undetected features are also important for a detection method, which makes the detection method unobjectionable and not easily deceived, because it is not easily noticeable. Face detection has this feature. It completely uses visible light to obtain facial image information. Unlike fingerprint detection or iris detection, it is necessary to use electronic pressure sensors to collect fingerprints, or use infrared to collect iris images. These special collection methods are easy. Being perceived, it is more likely to be deceived by pretense.

1.1.2 System Overview

Smart Eye camera is designed to focus on detecting and capturing frontal faces, it adopts high performance smart chip with deep learning technology, which can provide high precision face detection.

This product supports face, body, head-shoulder detection and capture.

1.1.3 Application Scenario

The camera can be used in parks, factories, supermarkets, community squares, conference centers, stadiums, schools, hospitals, residential areas, commercial streets, large farmers' markets, and other important parts of public events and gathering places, hotels (hotels), restaurants, entertainment venues, office buildings Surveillance and video recording for indoor and outdoor areas such as lobby entrances, elevators and other main passages.

1.1.4 Functions

Face Capture

Face capture is a software application that automatically captures faces from within a digital image or a video frame from a video source. Smart Eye cameras use advanced deep learning algorithms and are trained by a large number of face data sources, enabling the camera to locate faces quickly and accurately from the video source and capture facial images.

Intelligent Video System (IVS)

Support Face, body, head-shoulder detection and capture. Also with built-in intelligent video analytics, the camera has the ability to detect and analyze moving objects for improved video surveillance. The camera provides optional standard intelligence at the edge allowing detection of Perimeter, Single Virtual Fences, Double Virtual Fences, Loiter, Multi Loiter, Converse and Personnel Count

Smart Encode(H.265+)

Deliver high quality video without straining the network, Smart Encode H.265+ is the optimized implementation of H.265. The Smart H.265+ encoding technology includes a scene adaptive encoding strategy, dynamic GOP, dynamic ROI, flexible multi-frame reference structure and intelligent noise reduction, providing saving of up to 70% of bandwidth and storage when compared with standard H.265.

HEVC (H.265)

H.265 ITU-T VCEG is a new video coding standard. H.265 Following standard developed around the existing video coding standard H.264 , some retain the original technology , while some of the relevant technology to improve the new technology uses advanced technology to improve the relationship between the code stream , encoding quality , and the delay between algorithm complexity , optimize settings specific contents include : Improve compression efficiency , improve the robustness and error recovery capabilities, real-time to reduce the delay, reduce channel acquisition time and a random access delay , reduce complexity.

1.1.5 Installation

The camera is installed in the middle of the entrance of the channel, and the surrounding environment is unobstructed.

If you want to face be captured, and the horizontal deflection angle is less than 15° and the smaller is the better. The installation needs to have a slight angle of view to avoid obscuring the rear face when the person passes through the passage, and the vertical top view angle $\alpha=10^\circ\pm 3^\circ$.

Figure 1-1 Angle of installation

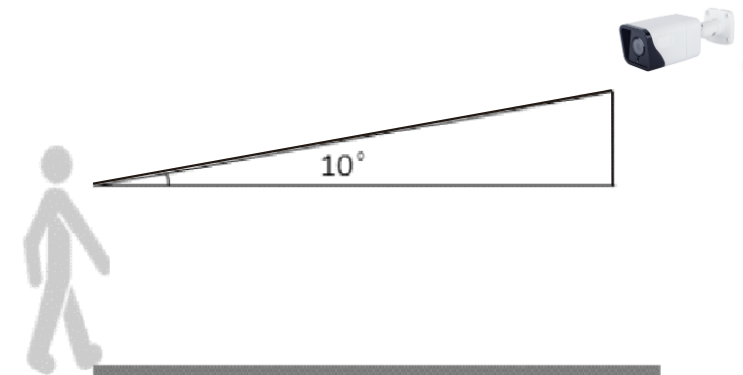

Height of installation:

The camera usually has a height of 1.8 meters to 2.3 meters. The best installation position during camera installation is that the camera is parallel to the collection face, or higher; keep the tilt angle not too large, the success rate of the face collection and the detection rate will be greatly increased. Improve, the camera usually has a height of 1.8 meters - 2.3 meters. The best installation position during the installation of the camera is that the camera is parallel to the collecting face, or higher; keep the tilt angle not too large, the face success rate and the comparison detection rate Will greatly improve.

Figure 1-2 Height of installation

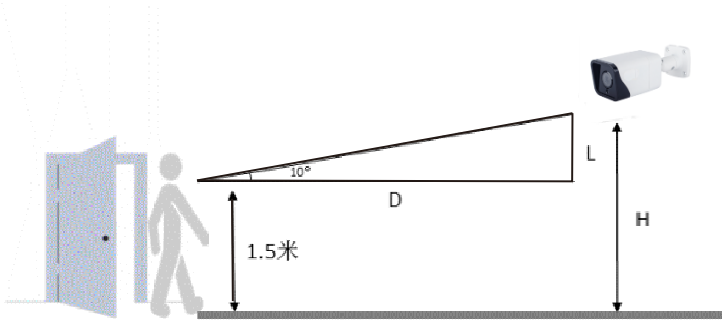

The height of the camera erection: $H=1.5+0.18*D$, 1.5 meters means that the height of the human head is averaged, and D is the monitoring distance.

Camera installation lighting problem:

The camera installation position should be adjusted according to the lighting and lighting conditions to adjust the position of the camera; if the camera is installed behind the light.

The direction of influence of light on the face is: light, backlight, side light, etc.;; camera installation position requires root face to light direction

To the light: the face is facing the light or the direction of the light

Backlighting: face facing away from light or light direction

Sidelight: the light on the left and right sides of the face, the light is higher than the light intensity before and after.

Table 1-1 Wide of observation

No.	Pixel	wide(m)
1	2 million	2.5
2	4 million	3.3
3	6 million	4
4	8 million	5

1.2 Appearance

Figure 1-3 Appearance of device (unit: mm)

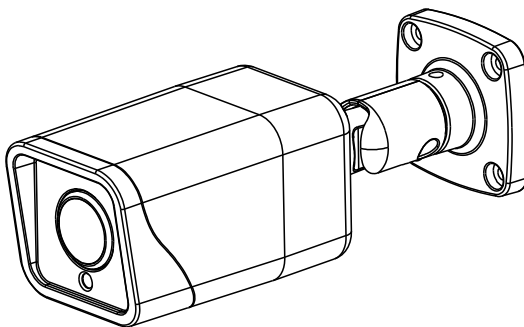
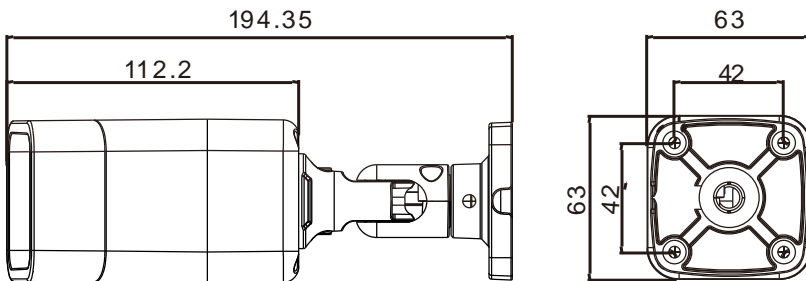

1.3 Login and Logout



CAUTION

You must use Internet Explorer 8 or a later version to access the web management system; otherwise, some functions may be unavailable.

Login system

Step 1 Open the Internet Explorer, enter the IP address of IP camera (default value: 192.168.0.120) in the address box, and press Enter.

The login page is displayed, as shown in Figure 1-4.

Figure 1-4 Login page

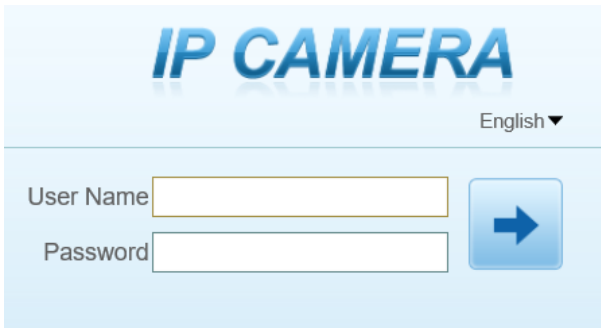

Step 2 Input the User and password.



NOTE

- The default name and password are both **admin**. Modify the password when you login the system for first time to ensure system security. After modifying password, you need to wait at least three minutes then power off to make sure modifying successfully . Or login the Web again to test the new password.
- You can change the system display language on the login page.

Step 3 Click Login arrow. The main page is displayed.

----End

logout

To logout of system, click  in the upper right corner of the main page, the login page is display after you log out of the system.

1.4 Main Page layout

On the main page, you can view real-time video, set parameter, Video parameter, Video control, and logout of the system. Figure 1-5 is shown the main page layout. Table 1-2 lists the elements on the main page layout.

Figure 1-5 Main page layout

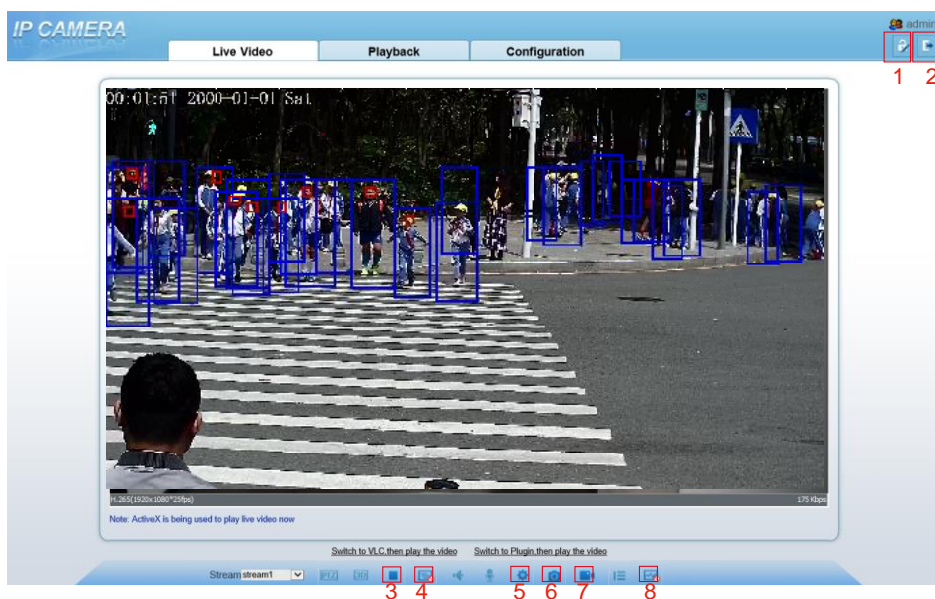



Table 1-2 Elements on the main page

No.	Element	Description
	Real-time video area	Real-time videos are played in this area. You can also set sensor parameters.
	Playback	You can query the playback videos in this area. NOTE Only when the SD card or NAS has videos that you can query the playback videos.

No.	Element	Description
	Device configuration	You can choose a menu to set device parameters, including the device information, audio and video streams, alarm setting, and privacy mask function.
	Stream	Choose stream mode from drop-list.
1	Change password	You can click  to change the password.
2	Log Out	You can click  to return to the login page.
3	Pause/play	Pause the live video or play the video.
4	Live/smooth	Switch the resolution of live video automatically.
5	Sensor	Set the sensor parameters.
6	Snapshot	Click the icon to snapshot the video and save the images to the specified location.
7	Local record	Record the video and save the file to the specified location.
8	Intelligent analysis	Open/close the intelligent analysis.



NOTE

- When the device accepts an alarm signal, the alarm icon will display within 10s in the

web management system. The alarm icon  is displayed. You can click  to view the alarm information.

----End

1.5 Change the Password

Description

You can click  to change the password for logging to the system.

Procedure

Step 1 Click  in the upper right corner of the main page.

The **Change Password** dialog box is displayed, as shown in Figure 1-6.

Figure 1-6 Modify Password dialog box

Change password

Old Password

New Password

Confirm

Password Requirements:

1. Greater than 7 characters.
2. Must use letters, numbers and special characters.
3. Password cannot be the same as username.
4. Password cannot be the username entered backwards.

OK Cancel

NOTE

- The change password page will be displayed if you don't change the default password when you login the system for the first time. User need to wait at least three minutes after changing password, and then restart the device. The password incorrect more than 3 times, please login again after 5 minutes

Step 2 Input the old password, new password, and confirmation password.

Step 3 Click **OK**.

If the message "Change own password success" is displayed, the password is successfully changed. If the password fails to be changed, the cause is displayed. (For example, the new password length couldn't be less than eight.)

Step 4 Click **OK**. The login page is displayed.

----End

1.6 Browse Video

User can browse the real-time video in the web management system.

Preparation

To ensure the real-time video can be play properly, you must perform the following operation when you login to the web for the first time:

Step 1 Open the Internet Explorer. Choose **Tools > Internet options > Security > Trusted sites > Sites**.

In the display dialog box, click **Add**, as shown in Figure 1-7.

Figure 1-7 Add the a trusted site

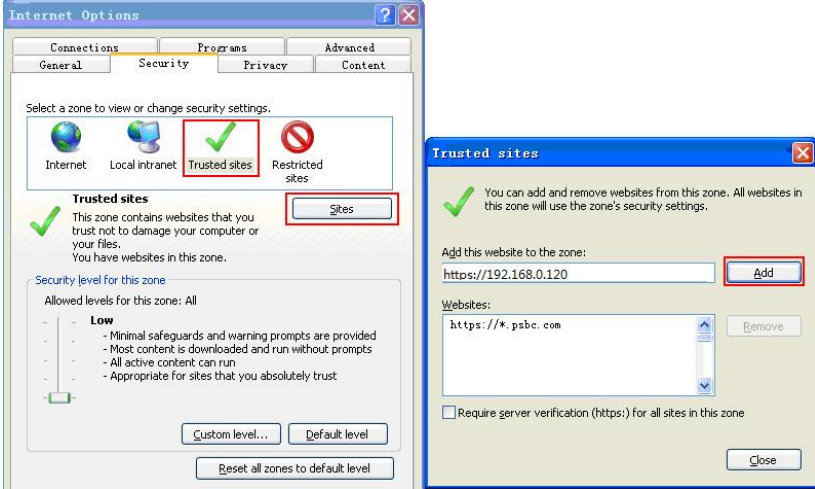

Step 2 In the Internet Explorer, choose **Tool > Internet Options > Security > Customer level**, and set Download unsigned ActiveX control and initialize and script ActiveX controls not marked as safe for scripting under ActiveX controls and plug-ins to Enable, as shown in Figure 1-8.

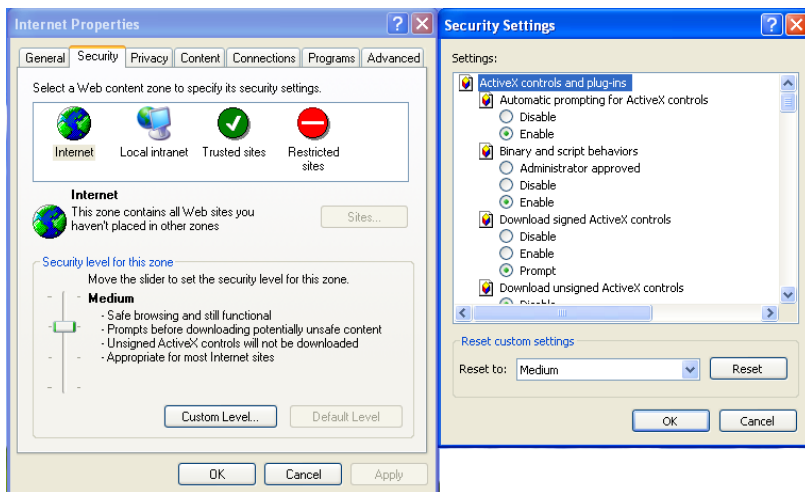
Figure 1-8 Configuring ActiveX control and plug-ins

Step 3 Download and install the player control as prompted.

 **NOTE**

- The login page is display when the control is loaded.

1.1.1 Install Plugins

You will be prompted with a message “Download and install the new plugin” will show as in Table 1-2, when you login to the web management system for the first time.

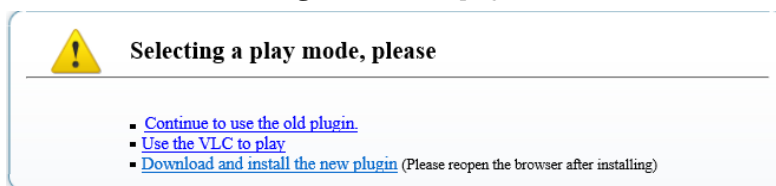
Figure 1-9 Install plugin

Procedure

- Step 1 Click the message, download and install the plugin follow the prompts.
- Step 2 During installing, user should close the browser.
- Step 3 Reopen the browser after installation.

----End

1.7 Setting Local Network Parameters

Description

Local network parameters include:

- IP protocol
- IP address
- Subnet mask
- Default gateway
- Dynamic Host Configuration Protocol (DHCP)
- Preferred Domain Name System (DNS) server
- Alternate DNS server
- MTU

Procedure

Step 1 Choose **Configuration > Device > Local Network**.

The **Local Network** page is displayed, as shown in Figure 1-10.

Figure 1-10 Local Network page

Local Network

Network Card ID	1
IP Protocol	IPv4
DHCP <input type="checkbox"/> OFF	
IP Address	192.168.0.120
Subnet Mask	255.255.255.0
Default Gateway	192.168.10.254
Preferred DNS Server	
Alternate DNS Server	
MTU(800-1500)	1500

Refresh Apply

Step 2 Set the parameters according to Table 1-3.

Table 1-3 Local network parameters

Parameter	Description	Setting
IP Protocol	IPv 4 is the IP protocol that uses an address length of 32 bits. IPv 6 is the IP protocol that uses an address length of 128 bits.	[Setting method] Select a value from the drop-down list box. [Default value] IPv4
DHCP	The device automatically obtains the IP address from the DHCP server.	[Setting method] Click the option button. NOTE To query the current IP address of the device, you must query it on the platform based on the device name.
DHCP IP	IP address that the DHCP server assigned to the device.	DHCP function is enabled.
IP Address	Device IP address that can be set as required.	[Setting method] Enter a value manually. [Default value] 192.168.0.121
Subnet Mask	Subnet mask of the network adapter.	[Setting method] Enter a value manually. [Default value] 255.255.255.0
Default Gateway	This parameter must be set if the client accesses the device through a gateway.	[Setting method] Enter a value manually. [Default value] 192.168.0.1
Preferred DNS Server	IP address of a DNS server.	[Setting method] Enter a value manually. [Default value] 192.168.0.1
Alternate DNS Server	IP address of a domain server. If the preferred DNS server is faulty, the device uses the alternate DNS server to resolve domain names.	[Setting method] Enter a value manually. [Default value] 192.168.0.2

Parameter	Description	Setting
MTU	Set the maximum value of network transmission data packets.	[Setting method] Enter a value manually. NOTE The MTU value is range from 800 to 1500, the default value is 1500, Please do not change it arbitrarily.

Step 3 Click **OK**.

- If the message "Apply success" is displayed, click **OK**. The system saves the settings. The message "Set network param's success, Please login system again" is displayed. Use the new IP address to log in to the web management system.
- If the message "Invalid IP Address", "Invalid Subnet Mask", "Invalid default gateway", "Invalid primary DNS", or "Invalid space DNS" is displayed, set the parameters correctly.



NOTE

- If you set only the **Subnet Mask**, **Default Gateway**, **Preferred DNS Server**, and **Alternate DNS Server** parameters, you do not need to login to the system again.
- You can click **Reset** to set the parameters again if required.

----**End**

2 Sensor Setting

2.1 Access the Sensor Setting Interface

Operation procedure:

- Step 1** On the web interface or client interface, move the cursor to the real-time video page and right-click on the page. A shortcut menu is displayed, as shown in Figure 2-1. Table 2-1 describes the sensor setting interface.

Figure 2-1 Sensor Setting interface

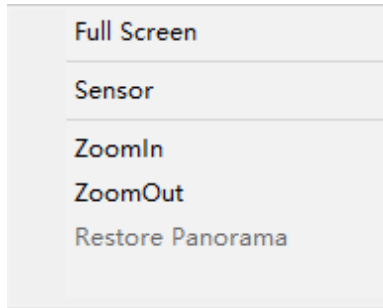

Table 2-1 Sensor parameters description

Parameter	Description
Full Screen	It enlarges and displays the image in full screen.
Sensor	It is used for configure the parameter set of front-end images.
Zoom In/Out	It zooms in/out images by electronic means. This function may also be used with the mouse wheel.

- Step 2** Choose **Sensor Configure** and the **Sensor Setting** dialog box appears.

----End

2.2 Time Segment

Operation procedure:

- Step 1** Click **Time Segment** tag on sensor setting interface, the time segment page is displayed, as shown in Figure 2-2.

Figure 2-2 Time Segment page

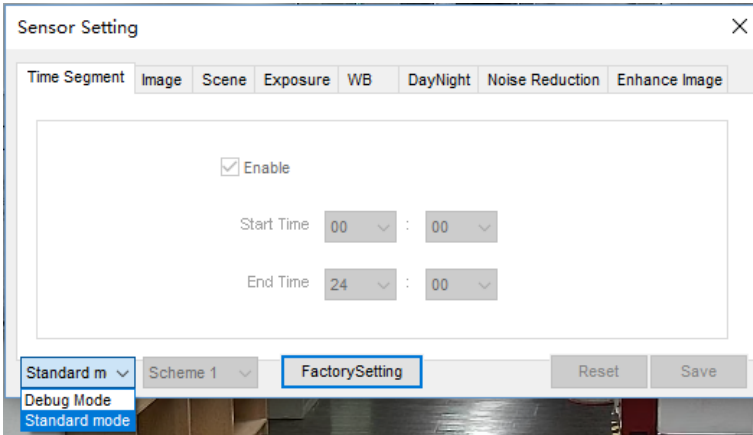

- Step 2** Choose Debug Model in the lower left corner to activate the sensor setting page.
- Step 3** Set the start time and end time.
- Step 4** Click Save to save the setting.

2.3 Image Setting

Figure 2-3 shows the image setting interface.

Figure 2-3 Image setting interface

Table 2-2 describes the image setting parameters.

Table 2-2 Image setting parameters description

Parameter	Description	Configuration Method
Brightness	It indicates the total brightness of an image. As the value increases, the image becomes brighter.	[Setting method] Drag the slider. [Default value] 50
Saturation	It indicates the color saturation of an image. As the value increases, the image becomes more colorful.	[Setting method] Drag the slider. [Default value] 50
Sharpness	It indicates the definition of an image. As the value increases, the image becomes more definitional.	[Setting method] Drag the slider. [Default value] 50
Contrast	It indicates the contrast between the bright part and the dark part of an image. As the value increases, the contrast increases.	[Setting method] Drag the slider. [Default value] 50

2.4 Scene Mode

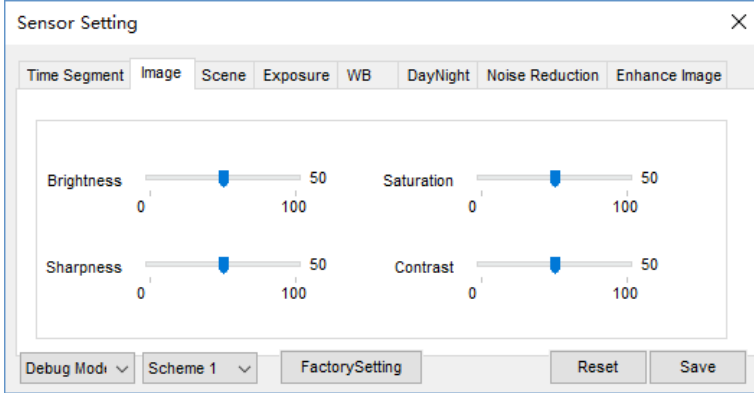
Figure 2-4 shows the scene mode interface.

Figure 2-4 Scene mode interface

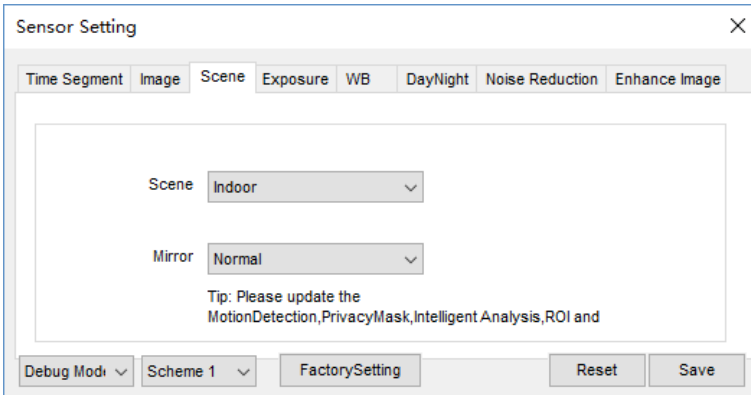

Table 2-3 describes the FFC mode parameters.

Table 2-3 FFC mode parameters description

Parameter	Description	Configuration Method
Scene	<p>It indicates the working mode of a camera..</p> <ul style="list-style-type: none"> Outdoor: It applies to outdoor scenarios. Indoor: It applies to indoor scenarios. 	<p>[Configuration method] Select from the drop-down list [Default value] Outdoor</p>
Mirror	<p>It is used to select the pixel location of an image.</p> <ul style="list-style-type: none"> Normal: The image does not flip. Horizontal: The image flips to the left and right. Vertical: The image flips up and down. Horizontal and vertical: The image rotates at 180 degrees. 	<p>[Setting method] Select a value from the drop-down list. [Default value] Normal</p>

Parameter	Description	Configuration Method
Aisle Mode	The image rotates 90 degrees clockwise when aisle mode is enabled.	[Setting method] Tick the Freeze status. [Default value] Disable
Freeze	It can be set to on or off . It is used to enable or disable the image freezing function of a camera.	[Setting method] Tick the Freeze status. [Default value] Disable

2.5 Exposure

Figure 2-5 shows the Exposure interface.

Figure 2-5 Exposure interface for IP camera

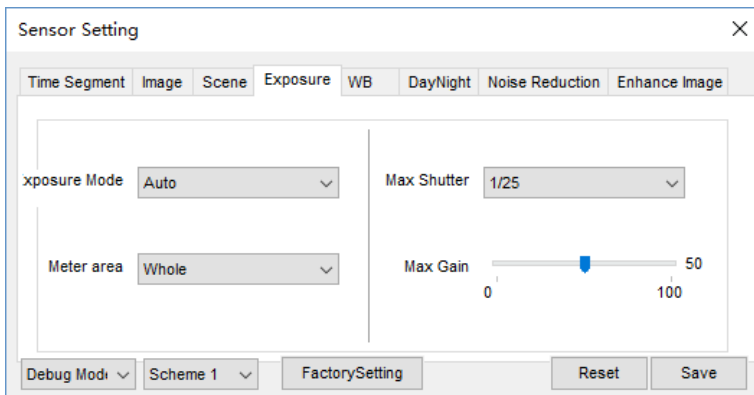



Table 2-4 describes Exposure parameters.

Table 2-4 Exposure parameters description

Parameter	Meaning	Configuration Method
Exposure Mode	<p>The exposure modes include:</p> <ul style="list-style-type: none"> • Auto: The system performs auto exposure based on the monitoring environment. • Manual: You can adjust the brightness of an image by setting the following three items: Shutter Setting, Iris Setting and Gain Setting. • Shutter Priority: You can set Shutter Setting to fixed values. The iris and gain are automatically adjusted by the system. • Iris Priority (for high speed dome): You can set Iris Setting to fixed values. The shutter and gain are automatically adjusted by the system. 	<p>[Setting method] Select a value from the drop-down list. [Default value] Auto</p>
Meter area	<p>It is used to select the metering area.</p> <ul style="list-style-type: none"> • Whole: During metering, all areas of an image have an equal weight, that is, all areas are involved in the metering. • Center pot: During metering, the central pot of an image has the highest weight. • Center Area: During metering, the middle area (1/2 of the total area) of an image has the highest weight, and other areas have the lowest weight. 	<p>[Setting method] Select a value from the drop-down list. [Default value] Whole</p>
Max Shutter	<p>The device automatically adjusts the shutter time based on the ambient brightness. The shutter time is less than or equal to the value of this parameter.</p>	<p>[Setting method] Select a value from the drop-down list. [Default value] 1/25</p>
Max Gain	<p>The device automatically adjusts the gain based on the external light. The gain is less than or equal to the value of this parameter.</p>	<p>[Setting method] Drag the slider. [Default value] 50</p>

Parameter	Meaning	Configuration Method
Iris (for high speed dome)	It is valid in manual mode and iris priority mode. You can adjust the brightness of an image by setting the iris. As the value increases, the brightness increases (when the shutter and gain remain the same). However, the camera movement automatically adjusts the shutter and gain in this mode. Therefore, the brightness of an image may not increase when you increase the iris.	[Setting method] Select a value from the drop-down list. [Default value] F1.6
Iris (for IP camera)	It is used to control the light admitted to the lens. The auto iris can be set to either of the following states: <ul style="list-style-type: none"> • Auto The iris is automatically adjusted to control the light admitted to the lens. • Open fully The iris is fully open. 	[Setting method] Select a value from the drop-down list. [Default value] Auto
Iris Speed	It indicates the auto adjustment speed of the iris. As the value increases, the speed increases. Excessive speed may cause instability.  NOTE This parameter is valid when the auto iris is enabled.	[Setting method] Drag the slider. [Default value] 50

2.6 WB Setting

Figure 2-6 shows the **WB Setting** interface.

Figure 2-6 WB Setting interface

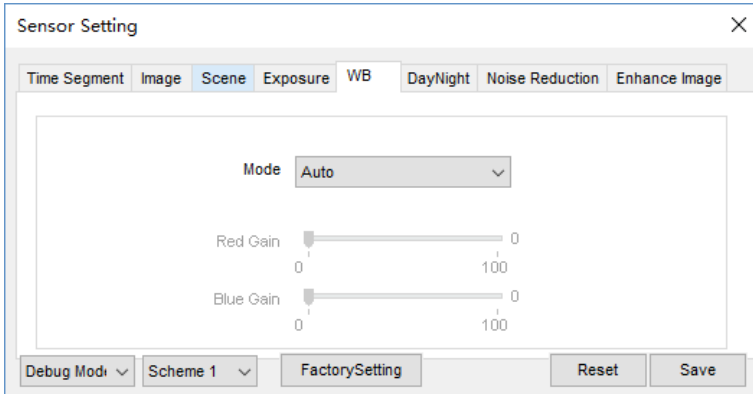



Table 2-5 describes **WB Setting** parameters.

Table 2-5 WB Setting parameters description

Parameter	Meaning	Configuration Method
Mode	<p>It is adjusted based on application scenarios to improve the fidelity of the image color.</p> <p>The WB modes include:</p> <ul style="list-style-type: none"> • Auto: In automatic white balance (WB) mode, the system automatically performs white balance based on the monitoring environment. • Tungsten • Fluorescent • Daylight • Shadow • Manual: In manual WB mode, you can manually select a WB mode based on the monitoring environment. 	<p>[Setting method] Select a value from the drop-down list. [Default value] Auto</p>
Red Gain	<p>It indicates the gain applied to red channels. As the value increases, the color temperature becomes lower.</p> <p> NOTE This parameter is valid when Manual Mode is set to Customized.</p>	<p>[Setting method] Drag the slider. [Default value] 0</p>

Parameter	Meaning	Configuration Method
Blue Gain	<p>It indicates the gain applied to blue channels. As the value increases, the color temperature becomes higher.</p> <p> NOTE This parameter is valid when Manual Mode is set to Customized.</p>	<p>[Setting method] Drag the slider. [Default value] 0</p>

2.7 Daynight

The day night mode settings vary based on device models. For details, see the following sections.

Figure 2-7 to Figure 2-10 shows the **DayNight Mode** interface.

Figure 2-7 DayNight Mode (1) interface

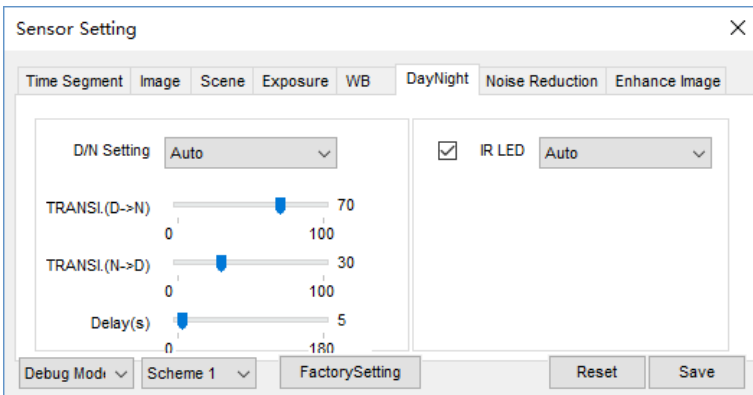

Figure 2-8 DayNight Mode (2) interface

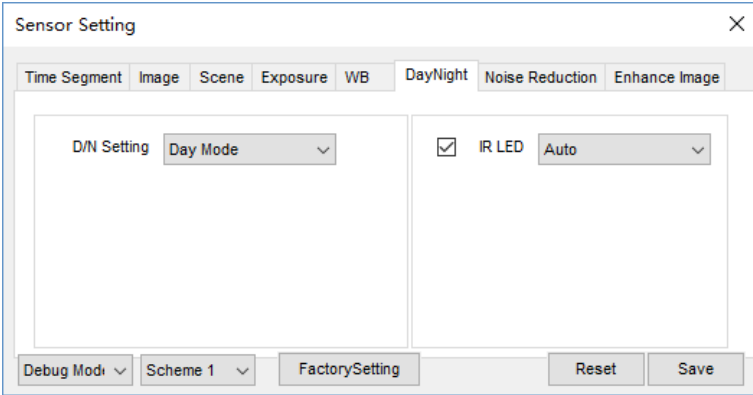

Figure 2-9 DayNight Mode (3) interface

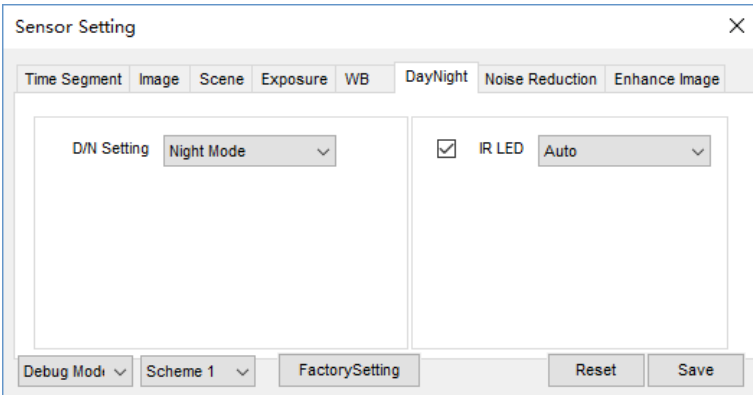

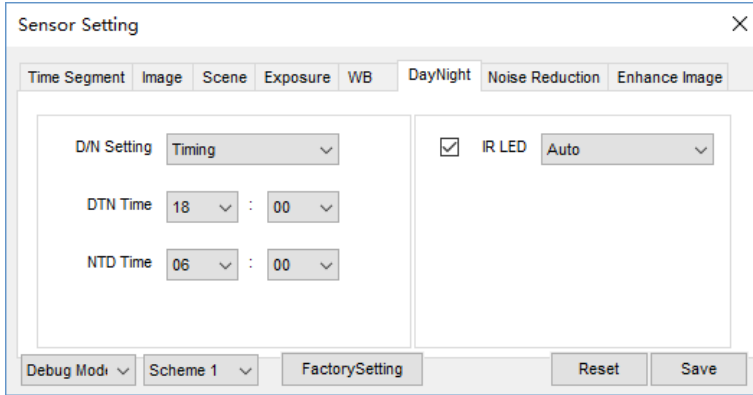



Figure 2-10 DayNight Mode (4) interface

Table 2-6 describes **DayNight Mode** parameters.

Table 2-6 DNR parameters description

Parameter	Meaning	Configuration Method
D/N Setting Mode	<p>It can be set to Auto, Day, Night or Timing.</p> <ul style="list-style-type: none"> • Auto mode The image color and filter status are automatically switched based on the ambient brightness. The filter prevents infrared light from entering the sensor in the day state and allows all types of light to enter the sensor in the night state. • Day mode The image is colored, and the filter is in the day state, preventing infrared light from entering the sensor. • Night mode The image is black and white, and the filter is in the night state, allowing infrared light to enter the sensor. • Timing Set day to night time and night to day time to switch the daynight mode. 	<p>[Setting method] Select a value from the drop-down list. [Default value] Auto</p>

Parameter	Meaning	Configuration Method
TRANSL.(D->N)(dB)	<p>It determines the day-to-night switching in auto mode. When the system gain is greater than the value of this parameter, the system enters the night mode.</p> <p> NOTE This parameter is valid in auto mode. The value of TRANSL.(D->N) must be greater than the value of TRANSL.(N->D).</p>	<p>[Setting method] Drag the slider. [Default value] 70</p>
TRANSL.(N->D)(dB)	<p>It determines the night-to-day switching in auto mode. When the system gain is smaller than the value of this parameter, the system enters the day mode.</p> <p> NOTE This parameter is valid in auto mode. The value of TRANSL.(D->N) must be greater than the value of TRANSL.(N->D).</p>	<p>[Setting method] Drag the slider. [Default value] 30</p>
Delay(s)	<p>The delay time of day to night or night to day.</p> <p> NOTE This parameter is valid in auto mode.</p>	<p>[Setting method] Drag the slider. [Default value] 0</p>
IR LED	<ul style="list-style-type: none"> • Auto: The infrared lamp is enabled or disabled based on the external environment identified by the light dependent resistor (LDR). • ON: The system enters the night mode forcibly. • OFF: The infrared lamp is disabled. The filter and image color are switched based on the external environment identified by the LDR. <p> NOTE This parameter is valid in auto mode.</p>	<p>[Setting method] Select a value from the drop-down list. [Default value] Auto</p>
Strength	<p>Strength of IR LED, as the value increases, the image becomes brighter.</p>	<p>[Setting method] Drag the slider. [Default value] 50</p>

Parameter	Meaning	Configuration Method
DTN Time	Time of day to night.	[Setting method] Select a value from the drop-down list. [Default value] 18:00
NTD Time	Time of night to day.	[Setting method] Select a value from the drop-down list. [Default value] 6:00

2.8 Noise Reduction

Figure 2-11 shows the Noise Reduction interface.

Figure 2-11 Noise Reduction interface(manual)

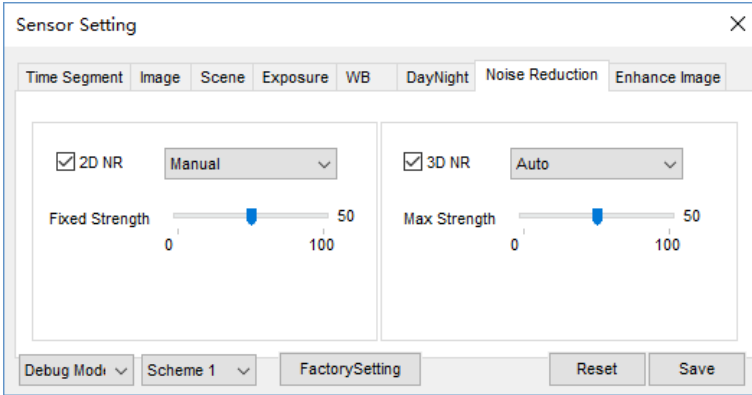

Figure 2-12 Noise Reduction interface(auto)

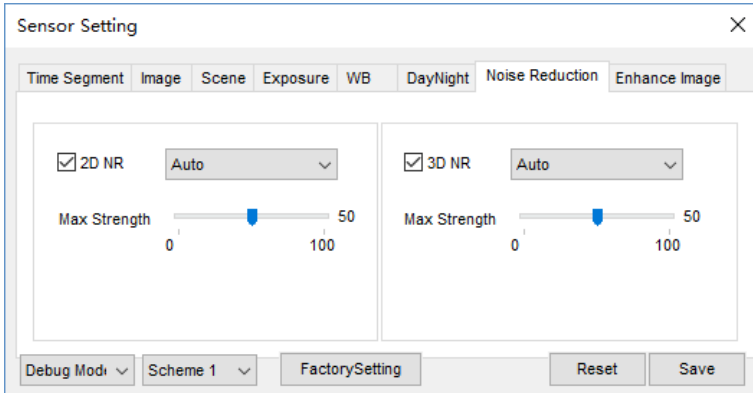

Table 2-7 describes DNR parameters.

Table 2-7 DNR parameters description

Parameter	Meaning	Configuration Method
2D NR	Reduce noise of image.	[Configuration method] Select from the drop-down list [Default value] Auto
3D NR	Reduce noise of image.	[Configuration method] Select from the drop-down list [Default value] Auto

Parameter	Meaning	Configuration Method
Max Strength	It is valid in auto noise filter mode. When the parameter value is 0 , the noise filter is disabled. When the parameter value is greater than 0 , the noise filter is enabled, and the system automatically adjusts the noise filter level based on the ambient brightness without exceeding the value of this parameter.	[Setting method] Drag the slider. [Default value] 50
Fixed Strength	It is valid in a manual noise filter mode.	[Setting method] Drag the slider. [Default value] 50

2.9 Enhance Image

Figure 2-13 shows the enhance image interface and Table 2-8 shows the enhance image parameter.

Figure 2-13 Enhance image interface

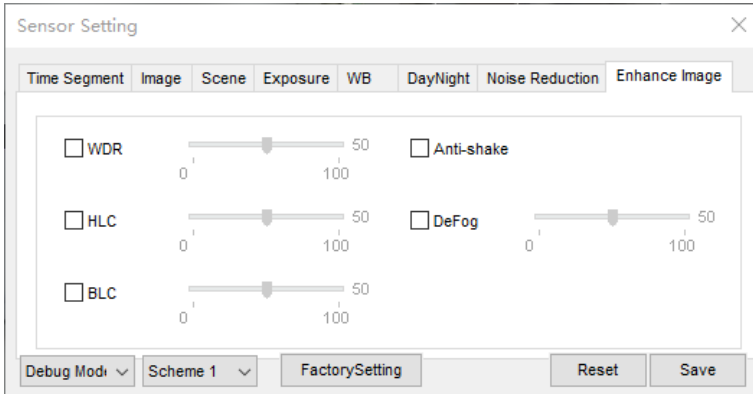

Table 2-8 Enhance image parameters description

Parameter	Meaning	Configuration Method
WDR	It is used to display the foreground and background at the same time in the environment with a large brightness difference. When the brightness difference is larger, you can increase the WDR level to obtain better image effect.	[Setting method] Tick the WDR mode and drag the slider. [Default value] 50
HLC	It provides a clearer view of an image in the highlight environment. When HLC is enabled, the total brightness of an image is reduced, allowing you to view objects in front of the highlight.	[Setting method] Tick the HLC mode and drag the slider. [Default value] 50
BLC	It provides a clearer view of an image in the backlight environment. When BLC is enabled, the total brightness of an image increases, allowing you to view objects in front of the backlight. Meanwhile, the objects behind the backlight are exposed excessively.	[Setting method] Tick the HLC mode and drag the slider. [Default value] 50

Parameter	Meaning	Configuration Method
Anti-shake	The shakes and visual angle of image will reduce when the camera shakes slightly and the anti-shake is enable.	[Setting method] Tick the Anti-shake mode.
DeFog	It provides a clearer view of an image in the fogged environment when Defog is enabled. As the value increases, the image becomes clearer.	[Setting method] Tick the Defog mode and drag the slider. [Default value] 50

3 Configure Face Detection

Click **Configuration > Face Detection**.

Step 1 The **Device Info** page is displayed, as shown in Figure 3-1

Figure 3-1 Face Detection interface

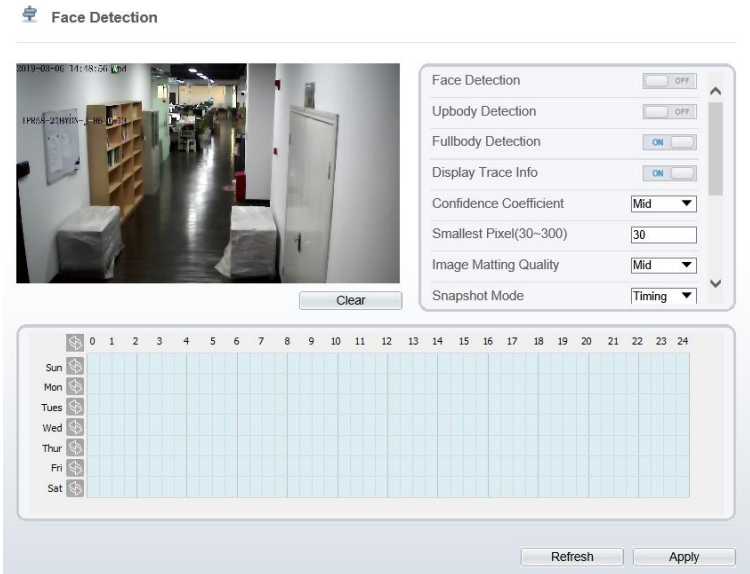

Step 2 Set the parameters according to Table 3-1

Table 3-1 Parameter of face detection

Parameter	Description	Setting
Face detection	Detect face of human	[Setting method] Enable the button [Default value] On
Upbody detection	Detect face and shoulder part of human	[Setting method] Enable the button [Default value] Off

Fullbody detection	Detect the human shape	[Setting method] Enable the button [Default value] Off
Display trace	Display the information of tracing	[Setting method] Enable the button [Default value] On
Confidence coefficient	Face detection sensitivity, the value range is high, medium, low, the larger the value is, the higher the sensitivity. The higher the sensitivity value is, the higher the detection rate will be, but the more false detection may occur, such as the false detection of the patterns on pedestrian clothes to adult faces.	[Setting method] Choose from drop -list [Default value] Medium
Smallest pixel	When the pixel of the face in the image is less than the set value (the minimum pixel for face recognition), it is not captured.	[Setting method] Input a number from 30 to 300 [Default value] 60
Snapshot mode	There are two types timing and optimal.	[Setting method] Choose from drop -list [Default value] Timing
Upload image interval	N/A	[Setting method] Input a number from 1 to 10 [Default value] 5
Yaw degree	Set face Angle to filter out Angle is too large face, it maybe not detect the face.	[Setting method] Input a number from 0 to 90 [Default value] 30
Tilt degree	N/A	[Setting method] Input a number from 0 to 90

		[Default value] 30
FTP upload image matting	Enable or disable.	[Default value] Disable
FTP upload whole image	Enable or disable.	[Default value] Disable
Algorithms library version	N/A	

----End

4 Intelligent Analysis

4.1 Perimeter

Description

The perimeter function refers to that an alarm is generated when the targets of specified types (such as person, car, and both person and car) enter the deployment area.

Procedure

- Step 1** Select **Intelligent Analysis > Perimeter** to access the **Perimeter** interface, as shown in Figure 4-1

Figure 4-1 Perimeter Setting Interface

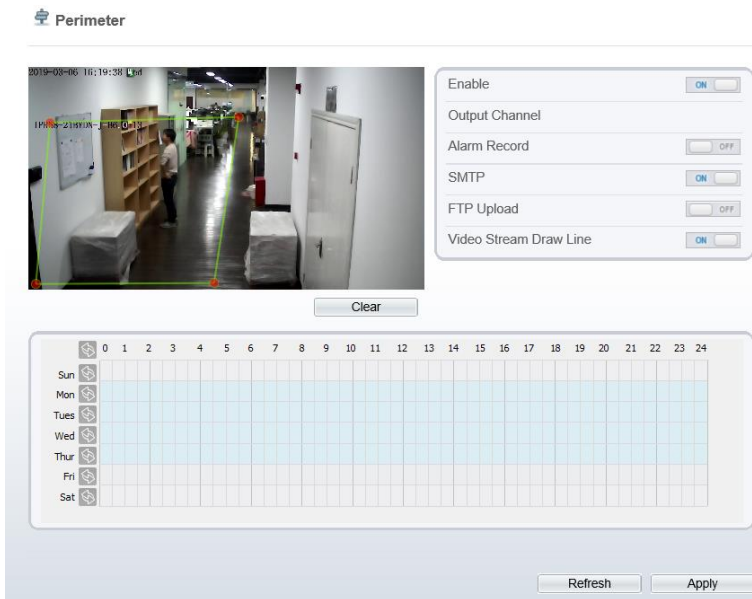

- Step 2** Set all parameters for perimeter. Table 4-1 describes the specific parameters.

Table 4-1 Perimeter Parameter Description

Parameter	Description	Setting
Enable	Enable the button to enable the alarm.	[How to set] Click Enable to enable. [Default value] OFF
Alarm Record	Enable the button to enable the alarm record.	[How to set] Click to enable Alarm Record. [Default value] OFF
SMTP	Enable the button to enable SMTP sever.	[How to set] Click to enable SMTP. [Default value] OFF
FTP Upload	Enable the button to enable File Transfer Protocol.	[How to set] Click to enable FTP Upload. [Default value] OFF
Video Stream Draw Line	Enable the button, the draw line will show at live video when the stream is stream 2.	[How to set] Click to enable Video Stream Draw Line. [Default value] OFF

Step 3 Set a deployment area

Move the cursor to the drawing interface and click to generate a point, move the cursor to draw a line, and then click to generate another point. This is how a line is generated. In this way, continue to draw lines to form any shape, and right-click to finish line drawing.

 **NOTE**

- A drawn line cannot cross another one, or the line drawing fails.
- Any shape with 8 sides at most can be drawn.
- The quantity of deployment areas is not limited yet and will be described in future when a limit is applied.

Step 4 Set deployment time

Method 1: Click left mouse button to select any time point within 0:00-24:00 from Monday to Sunday as shown in Figure 4-2.

Method 2: Hold down the left mouse button, drag and release mouse to select the deployment time within 0:00-24:00 from Monday to Sunday.

 **NOTE**

When you select time by dragging the cursor, the cursor cannot be moved out of the time area. Otherwise, no time can be selected.

Method 3: Click  in the deployment time page to select the whole day or whole week.

Deleting deployment time: Click  again or inverse selection to delete the selected deployment time.

Figure 4-2 Deployment Time Setting Interface



----End

4.2 Single Virtual Fence

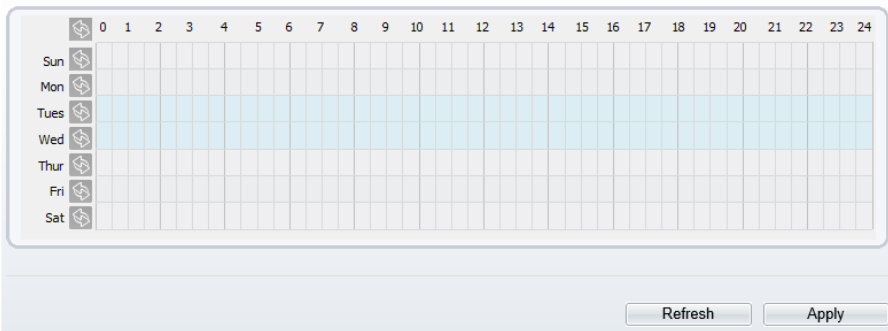
Description

A single virtual fence is a line that is set at a concerned position within the monitored field of view and specifies the forbidden travel direction, an alarm is generated when the targets of specified types (such as person or car) cross this line.

Procedure

- Step 1** Select **Intelligent Analysis > Single Virtual Fence** to access the **Single Virtual Fence** setting interface, as shown in Figure 4-3.

Figure 4-3 Single Virtual Fence Setting Interface

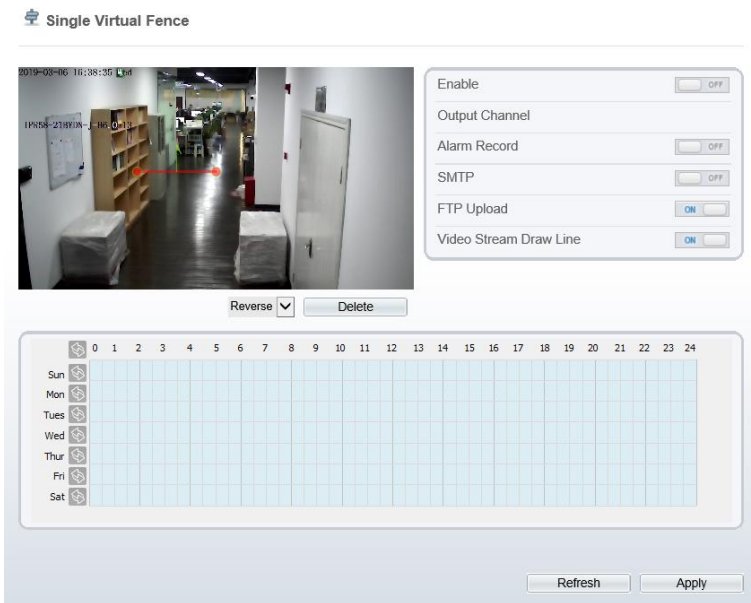

- Step 2** Set all parameters for the single virtual fence. Table 4-2 describes the specific parameters.

Table 4-2 Description of Parameters for Single Virtual Fence

Parameter	Description	Setting
Enable	Enable the button to enable the alarm.	[How to set] Click Enable to enable . [Default value] OFF
Alarm Record	Enable the button to enable the alarm record.	[How to set] Click to enable Alarm Record. [Default value] OFF
SMTP	Enable the button to enable SMTP sever.	[How to set] Click to enable SMTP. [Default value] OFF
FTP Upload	Enable the button to enable File Transfer Protocol.	[How to set] Click to enable FTP. [Default value] OFF
Video Stream Draw Line	Enable the button, the draw line will show at live video when the stream is stream 2.	[How to set] Click to enable Video Stream Draw Line. [Default value] OFF

Step 3 Set a deployment area

Drawing a line: move the cursor to the drawing interface, hold down the left mouse button, and move the cursor to draw a line. When you release the left mouse button, a single virtual fence is generated.

Setting a single virtual fence: click a line (and the trip line turns red) to select the single virtual fence and set its direction as **positive**, **reverse** or **bidirectional**, or **delete the selected** line. You can also press and hold left mouse button at the endpoint of a single virtual fence and move the mouse to modify the position and length of this single virtual fence. You can right-click to delete the single virtual fence

 **NOTE**

- A single virtual fence is not within any deployment area, therefore, when an alarm is generated, the trace always exists. Only when the target object moves out of the field of view, the trace disappears.
- Try to draw the single virtual fence in the middle, because the recognition of a target takes time after target appearance on the screen and an alarm is generated only when the object is recognized to have crossed the single virtual fence.
- The single virtual fence which detects person foot as the recognition target cannot be too short, because a short single virtual fence tends to miss targets.

Step 4 Set deployment time

Details please refer to *4.1 Step 4*

---End

4.3 Double Virtual Fences

Description

Double virtual fences refer to two lines that are set at a concerned special position within the field of view and specify the forbidden travel direction. when the targets of specified types (such as person or car) move along the set travel direction and cross these lines in a certain order (line 1 followed by line 2) in pass max time, an alarm is generated.

Procedure

- Step 1** Select **Intelligent Analysis > Double Virtual Fences** to access the **Double Virtual Fences** setting interface, as shown in Figure 4-4.

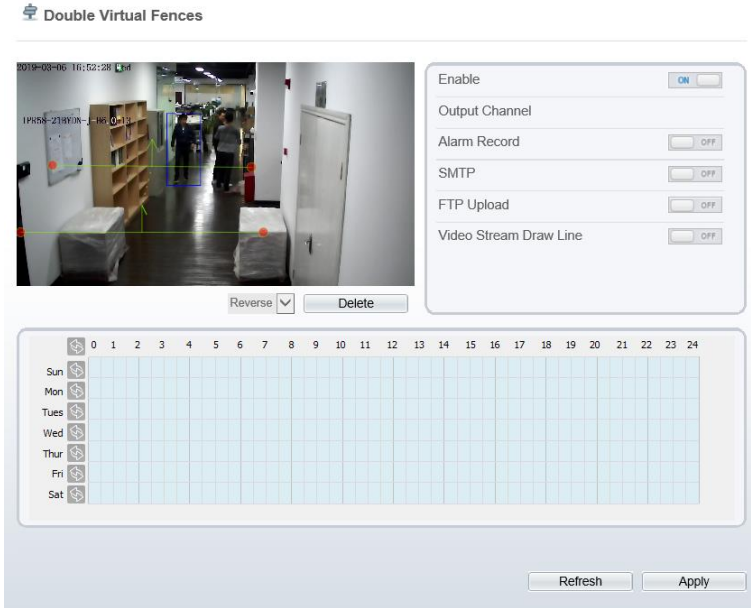
Figure 4-4 Double Virtual Fences Setting Interface

Step 2 Set all parameters for the double virtual fences. Table 4-3 describes the specific parameters.

Table 4-3 Description of Parameters for Double Virtual Fence

Parameter	Description	Setting
Enable	Enable the button to enable the alarm.	[How to set] Click Enable to enable. [Default value] OFF
Alarm Record	Enable the button to enable the alarm record.	[How to set] Click to enable Alarm Record. [Default value] OFF
SMTP	Enable the button to enable SMTP sever.	[How to set] Click to enable SMTP. [Default value] OFF

Parameter	Description	Setting
FTP Upload	Enable the button to enable File Transfer Protocol.	[How to set] Click to enable FTP. [Default value] OFF
Video Stream Draw Line	Enable the button, the draw line will show at live video when the stream is stream 2.	[How to set] Click to enable Video Stream Draw Line. [Default value] OFF

Step 3 Set a deployment area

Drawing a line: Move the cursor to the drawing interface, hold down the left mouse button, and move the cursor to draw two lines. When you release the left mouse button, two numbered virtual fences are generated. Choose either of the double virtual fences to set the direction to **Positive** or **Reverse**.

Setting double virtual fences: Click one of the double virtual fences (and the virtual fence turns red) to select this virtual fence and set the direction to **Positive** or **Reverse**, or delete the selected line. You can also press and hold left mouse button at the endpoint of a virtual fence and move the mouse to modify the position and length of this virtual fence.

NOTE

- The two virtual fences are in sequential order. An alarm is generated only when a target crosses virtual fence 1 and then virtual fence 2 within the set maximum passing time.
- The double virtual fences are not within any deployment area, therefore, when an alarm is generated, the trace always exists. Only when the target object moves out of the field of view, the trace disappears.
- Try to draw double virtual fences in the middle, because the recognition of a target takes time after target appearance on the screen and an alarm is generated only when the object is recognized to have crossed the double virtual fences.
- The double virtual fences which detect person foot as the recognition target cannot be too short, because short double virtual fences tend to miss targets.

Step 4 Set deployment time

Details please refer to *4.1 Step 4*

----End

4.4 Multiple Loiter

Description

Multiple loiter allows setting the shortest loitering time for multiple targets of specified type (such as person or car) within the deployment area in the field of view. When the loitering time of the multiple targets within this area meets the set shortest loitering time, an alarm is generated.

Procedure

- Step 1** Select **Intelligent Analysis > Multi Loiter** to access the **Multi Loiter** setting interface, as shown in Figure 4-5.

Figure 4-5 Multi Loiter Setting Interface

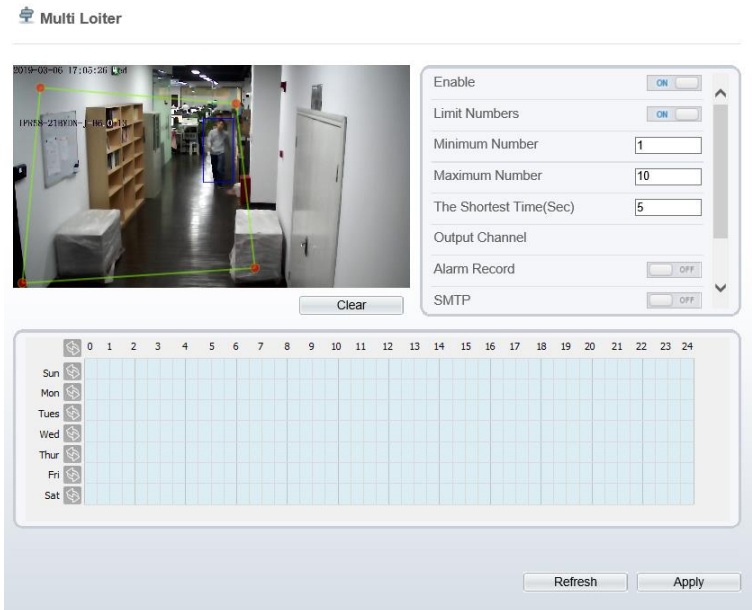

- Step 2** Set all parameters for multiple loitering. Table 4-4 describes the specific parameters.

Table 4-4 Multiple Loitering Parameter Description

Parameter	Description	Setting
Enable	Enable the button to enable the alarm.	[How to set] Click Enable to enable . [Default value] OFF
Limit Target Size	The target size for triggering an effective alarm is set based on the actual target size. The minimum size is 1000 square centimeters and the maximum 100000 square centimeters. When setting the target size, you need to well set “Real size in scene” in advanced parameters, otherwise no alarms may be generated.	[How to set] Click to enable Limit Target Size. [Default configuration] OFF
Limit Numbers	When Limit Numbers is set to OFF, an alarm is generated no matter how many people loiter. When Limit Numbers is set to ON, if the minimum number is set to 2 and the maximum number is set to 3, an alarm is generated for 2-3 people loitering. Other settings are the same as loitering.	[How to set] Click to enable Limit Numbers.
The Shortest Time (Sec)	The time that a target object spends in loitering cannot be less than the shortest loitering time. Setting range: 5-60 seconds.	[How to set] Enter a value in the area box. [Default value] 10s
Output Channel	If you check to set the Output Channel and the device is connected to an external alarm indicator, the alarm indicator signals when an alarm is triggered.	[How to set] Click to select an ID.
Alarm Record	Enable the button to enable the alarm record.	[How to set] Click to enable Alarm Record. [Default value] OFF

Parameter	Description	Setting
SMTP	Enable the button to enable SMTP sever.	[How to set] Click to enable SMTP. [Default value] OFF
FTP Upload	Enable the button to enable File Transfer Protocol.	[How to set] Click to enable FTP Upload. [Default value] OFF
Trace Linkage	Enable the button to enable trace linkage, when the relevant behaviors are detected, the camera will trace the car or person until the object is disappear, then the camera come back the original position.	[How to set] Click to enable Trace Linkage. [Default value] OFF
Video Stream Draw Line	Enable the button, the draw line will show at live video when the stream is stream 2.	[How to set] Click to enable Video Stream Draw Line. [Default value] OFF

Step 3 Set a deployment area

Move the cursor to the drawing interface and click to generate a point, move the cursor to draw a line, and then click to generate another point. This is how a line is generated. In this way, continue to draw lines to form any shape, and right-click to finish line drawing.



NOTE

- A drawn line cannot cross another one, or the line drawing fails.
- Any shape with 8 sides at most can be drawn .
- The quantity of deployment areas is not limited yet and will be described in future when a limit is applied.

Step 4 Set deployment time

Details please refer to *4.1 Step 4*.

----End

4.5 Converse

Description

Converse allows setting the travel direction criteria for a target within an area on the video screen. When a target of specified type (such as people or car) within this area moves in the set travel direction, an alarm is generated.

Procedure

Step 1 Select **Intelligent Analysis > Converse** to access the **Converse** setting interface, as shown in Figure 4-6.

Figure 4-6 Converse Setting Interface

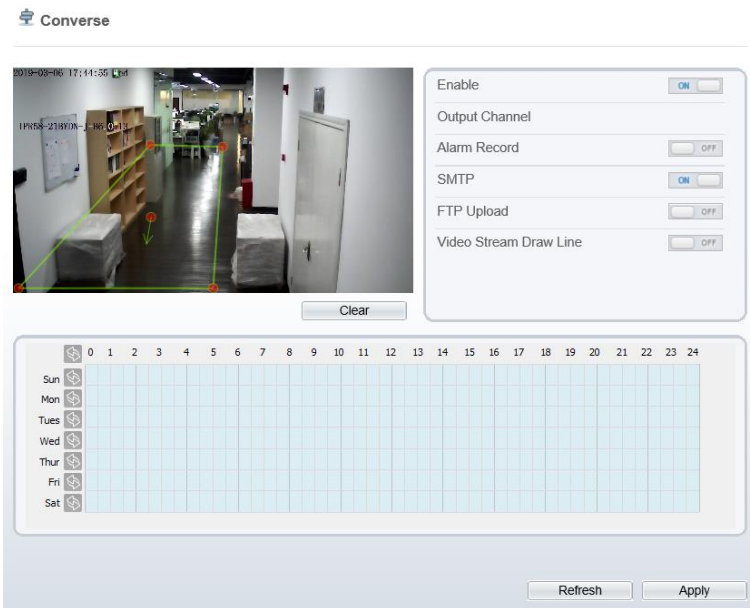

Step 2 Set all parameters for converse. Table 4-5 describes the specific parameters.

Table 4-5 Converse Parameter Description

Parameter	Description	Setting
Enable	Enable the button to enable the alarm.	[How to set] Click Enable to enable . [Default value] OFF

Parameter	Description	Setting
Alarm Record	Enable the button to enable the alarm record.	[How to set] Click to enable Alarm Record. [Default value] OFF
SMTP	Enable the button to enable SMTP sever.	[How to set] Click to enable SMTP. [Default value] OFF
FTP Upload	Enable the button to enable File Transfer Protocol.	[How to set] Click to enable FTP Upload. [Default value] OFF
Video Stream Draw Line	Enable the button, the draw line will show at live video when the stream is stream 2.	[How to set] Click to enable Video Stream Draw Line. [Default value] OFF

Step 3 Set a deployment area

Move the cursor to the drawing interface and click to generate a point, move the cursor to draw a line, and then click to generate another point. This is how a line is generated. In this way, continue to draw lines to form any shape, and right-click to finish line drawing, move the arrow in the field can set the direction of converse.



NOTE

- A drawn line cannot cross another one, or the line drawing fails.
- Any shape with 8 sides at most can be drawn .
- The quantity of deployment areas is not limited yet and will be described in future when a limit is applied.

Step 4 Set deployment time

Details please refer to *4.1 Step 4*.

----End

4.6 Personnel Count

Description

Personnel count is used for counting the number of people which go through the area.

Procedure

Step 1 Select **Intelligent Analysis > Personnel Count** to access the **Converse** setting interface, as shown in Figure 4-7.

Figure 4-7 Personnel Count Setting Interface

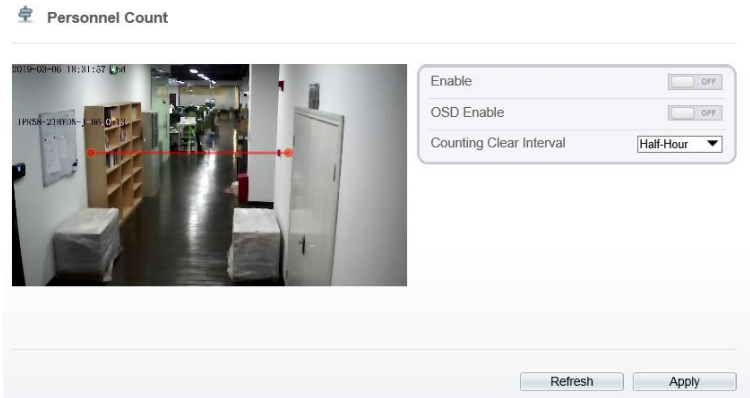

Table 4-6 Personnel Count Parameter Description

Parameter	Description	Setting
Enable	Enable the button to enable the personnel count	[How to set] Click Enable to enable . [Default value] OFF
OSD Enable	Enable the button to show counting on live video screen.	[How to set] Click to enable OSD Enable [Default value] OFF
Counting Clear Interval	There are five types to choose: 10 min , half-hour, 1 hour, 12 hours and 1 day.	[How to set] Choose one from the drop-list [Default value] Half-hour

Step 2 Set a deployment area

Drawing a line: move the cursor to the drawing interface, hold down the left mouse button, and move the cursor to draw a line. When you release the left mouse button, a single virtual fence is generated.

You can also press and hold left mouse button at the endpoint of a single virtual fence and move the mouse to modify the position and length of this single virtual fence. You can right-click to delete the personnel count fence

----End